

TEXAS METAL BUILDINGS
P.O. Box 1495

Aransas Pass, 78335
TX
PH: 361-758-3030
FX: 361-758-4631
Jeff@TexasMetalBuildings.com
TexasMetalBuildings.com

PURCHASE ORDER: PAGE 1 OF 3
DATE: 12/22/2008 TIME: 12:56 PM
CUSTOMER: Jeff Nibert
Revision No: 10
JOB NUMBER: TX3055
SALES PERSON: Jeff Nibert



BUILDING SPECIFICATIONS

BUILDING TYPE:	Partially sheeted to remain open
WIDTH :	24'
LENGTH :	36'
FSW HEIGHT:	10'
BSW HEIGHT:	9'
ROOF SLOPE:	0.5 : 12
FRAME TYPE:	Clear span
FRAME PROFILE:	Single slope
SW BAYS: 1 x 24', 1 x 12'	
LEW SHEETING:	Sheeted
REW SHEETING:	Sheeted
FSW SHEETING:	Open
BSW SHEETING:	Sheeted

CUSTOMER INFORMATION:

NAME:	Jeff Nibert
COMPANY:	Texas Metal Buildings
ADDRESS:	P.O. Box 1495
CITY:	Aransas Pass
ZIP:	78335
PHONE:	(361) 758-3030
CELL: (361) 739-4853	WORK:
FAX:	(361) 758-4631
E-MAIL:	Jeff@TexasMetalBuildings.com
PROJECT:	24 x 36 Shedrow
SHIP TO:	
Seguin, Texas, 78155	
COUNTY:	Guadalupe

DESIGN LOADS AND CODES

LIVE LOAD:	20.0
WIND LOAD:	90
BUILDING CODE:	IBC 06
GROUND SNOW:	12.0
SEISMIC COEF:	0.197
SEISMIC ZONE:	0
EXPOSURE:	B
COLLATERAL:	0.5
HIGH WIND:	
Building is not 100MPH or Higher	

WALL DATA

GAUGE:	26
PROFILE:	PBR
COLOR:	Colony Green
TRIM COLOR:	Fern Green
F.O. Cover Trim:	Standard
BASE TRIM:	no
BASE TYPE:	Girt
CONCRETE NOTCH:	yes
FASTENERS:	Premium
WAINSCOT:	no

INSET BAYS

LEW: no	Sheeted
REW: no	

ROOF SHEETING

GABLE EXT.

LEW: 0'	FSW: Panel shear
REW: 0'	BSW: Panel shear

WALL BRACING

EAVE EXT.

FSW: 0'	LEW: Bearing frame
BSW: 0'	REW: Bearing frame

END FRAME TYPE

ROOF DATA

GAUGE:	26
PROFILE:	PBR
COLOR:	Galvalume
TRIM COLOR:	Fern Green
CLOSURE PACKAGE:	Pro-Package
SCULPTURED RAKE:	Included
SCULPTURED EAVE:	Included
SEALANT PACKAGE:	Pro-Package
FASTENERS:	Premium
UL 90 ROOF:	Included

FRAMED OPENINGS

LEW:
REW:
FSW:
BSW:

THIS QUOTE IS GOOD UNTIL 1/11/2009 ONLY AND MUST HAVE ALL PAPERWORK COMPLETED ON OR BEFORE ORDER DATE
Due to current steel market volatility we are not able to honor pricing beyond "order-by" dates. The current steel market is changing rapidly and we are not able to forecast when prices will stabilize. ONLY WHEN ORDER IS RELEASED FOR FABRICATION will the current/updated price be held. If the order is delayed by customer for any reason, the order is subject to re-pricing. Price of alternates will be added if checked but is not included in the proposal total. Deposit is non-refundable - please check your order for accuracy and completeness.
Jeff Nibert REV. NO.: 10

TEXAS METAL BUILDINGS
P.O. Box 1495

Aransas Pass, 78335
TX
PH: 361-758-3030
FX: 361-758-4631
Jeff@TexasMetalBuildings.com
TexasMetalBuildings.com

PURCHASE ORDER: PAGE 2 OF 3
DATE: 12/22/2008 TIME: 12:56 PM
CUSTOMER: Jeff Nibert
Revision No: 10
JOB NUMBER: TX3055
SALES PERSON: Jeff Nibert



PARTIAL WALL ELEVATIONS

LEW OPEN TO:	
REW OPEN TO:	
FSW OPEN TO:	
BSW OPEN TO:	

OPTIONAL (not included unless indicated)

	PRICE	INCLUDED (Y/N)
#1 - GUTTER / DOWNSPOUTS	\$475.31	
#2 - 8 FOOT WALL LINER (WHITE) 26 GA. LOW RIB	\$1,235.58	
#3 - FULL WALL LINER (WHITE) 26 GA. LOW RIB	\$1,360.81	
#4 - ROOF LINER (WHITE) 26 GA. LOW RIB	\$3,350.30	
#5 - ROOF PANEL COLOR	\$135.07	

INSULATION (not included unless indicated)

	PRICE	INCLUDED (Y/N)
#1 - ROOF INSULATION 3 inch WMP/VRV Reinforced	\$360.14	
#2 - WALL INSULATION 3 inch WMP/VRV Reinforced	\$400.22	
#3 - ROOF INSULATION 4 inch WMP/VRV Reinforced	\$425.08	
#4 - WALL INSULATION 4 inch WMP/VRV Reinforced	\$472.39	
#5 - ROOF INSULATION 6 inch WMP/VRV Reinforced	\$580.55	
#6 - WALL INSULATION 6 inch WMP/VRV Reinforced	\$645.16	
INSULATION SHIPPING	\$0.00	

ACCESSORIES INCLUDED IN PRICE IF NOTED

	QUAN.	EACH	TOTAL PRICE

SECONDARY FRAMING MEMBER DETAILS

FSW:	Flush	TYPE:	Zee	SIZE:	8 "	COLOR:	Red oxide
BSW:	Flush	TYPE:	Zee	SIZE:	8 "	COLOR:	Red oxide
LEW:	Flush	TYPE:	Zee	SIZE:	8 "	COLOR:	Red oxide
REW:	Flush	TYPE:	Zee	SIZE:	8 "	COLOR:	Red oxide
ROOF:	Bypass	TYPE:	Heavy Zee	SIZE:	8 "	COLOR:	Red oxide
FRAMING:	I-Beam	TYPE:	Built-Up (welded sections)		COLOR:	Red oxide	

THIS QUOTE IS GOOD UNTIL 1/11/2009 ONLY AND MUST HAVE ALL PAPERWORK COMPLETED ON OR BEFORE ORDER DATE
 Due to current steel market volatility we are not able to honor pricing beyond "order-by" dates. The current steel market is changing rapidly and we are not able to forecast when prices will stabilize. ONLY WHEN ORDER IS RELEASED FOR FABRICATION will the current/updated price be held. If the order is delayed by customer for any reason, the order is subject to re-pricing. Price of alternates will be added if checked but is not included in the proposal total. Deposit is non-refundable - please check your order for accuracy and completeness.
 Jeff Nibert REV. NO.: 10

TEXAS METAL BUILDINGS
P.O. Box 1495

Aransas Pass, 78335
TX
PH: 361-758-3030
FX: 361-758-4631
Jeff@TexasMetalBuildings.com
TexasMetalBuildings.com

PURCHASE ORDER: PAGE 3 OF 3
DATE: 12/22/2008 TIME: 12:56 PM
CUSTOMER: Jeff Nibert
Revision No: 10
JOB NUMBER: TX3055
SALES PERSON: Jeff Nibert



ORDER INFORMATION

DRAWING TYPE:	N.A.
DRAWING SETS:	3 SETS OF PLANS
DESIGN CALCS:	0 SETS OF DESIGN CALCULATIONS
CONCRETE DESIGN:	no (If YES full slab only - no open floor)
DETAIL PLANS:	Included as standard

STANDARD DEFLECTION LIMITS

EW Columns/Rafters: 120/180L:120W
Wall Girts: 90
Roof Purlins: 180L:120W
Roof Panel: 90L:90W
Rigid Frame (H): 60
Rigid Frame (V): 180

CRANE LOADING:

Brackets and/or Auxillary Columns:	
Capacity (TONS)	N.A.
Runway Length (FT/M)	N.A.
(A) Runway Height (FT/M)	N.A.
(B) Runway Beam SIZE (IN/CM)	N.A.
(C) Rail Size (IN/CM)	N.A.
(D) Top of Crane to Bottom of Wheel	N.A.
Approx. Crane Span (Wheel-to-Wheel) (FT/M)	N.A.
Crane Loading Notes: Crane Systems and Runways by others. We include only the loads as specified above. Brackets or Columns are included ONLY if noted above. The above noted dimensions are approximate - under no circumstances should this information be used to order your crane(s). The use of brackets, auxiliary columns and bracing will be determined by us upon final engineering. FOR CONSTRUCTION drawings will be completed ONLY when we have received the required crane manufacturer's specifications.	

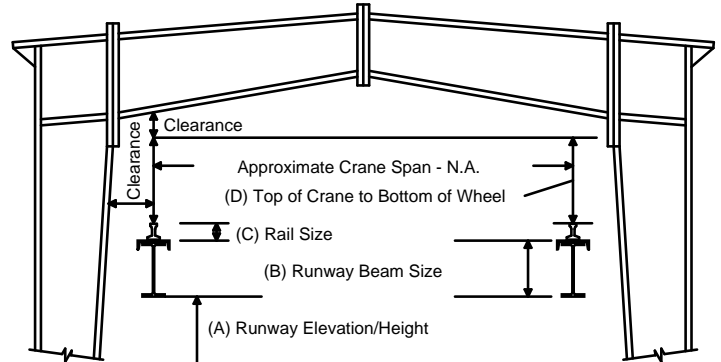

Special Job Notes: Field located items, (windows, doors, vents etc.) do not show on approval drawings
 Optional: (2) Commercial Duty Rollup door(s) Size 10 x 10 add \$1,260.00
 Optional: Hot-dipped Galvanized Main Frame (all primary structure) add \$460.00
 Optional: Pre-Galvanized Secondary Structure (all purlins, girts and angles) add \$400.00

WE PROPOSE TO FURNISH THE FOLLOWING MATERIALS COMPLETE IN ACCORDANCE WITH THE ABOVE SPECIFICATIONS AND GENERAL TERMS AND CONDITIONS OF CONTRACT FOR THE SUM OF:

MATERIAL F.O.B. JOB SITE - FREIGHT INCLUDED:	\$7,065.71
SALES TAX:	Not Included
TOTAL BUILDING COST:	\$7,065.71
BUILDING DEPOSIT:	\$2,000.00
BALANCE ON DELIVERY:	\$5,065.71

ACCEPTANCE OF PURCHASE ORDER

I HAVE READ AND UNDERSTAND THE GENERAL CONDITIONS OF THE CONTRACT AND HEREBY AUTHORIZE TEXAS METAL BUILDINGS TO BEGIN THE WORK SPECIFIED. THIS IS CONTRACT VALID ONLY WHEN ACCEPTED BY AN OFFICER OF TEXAS METAL BUILDINGS. BY SIGNING BELOW, I AGREE TO THE PRICES, SPECIFICATIONS, TERMS, AND CONDITIONS AS STATED IN THE GENERAL CONDITIONS OF CONTRACT AND FURTHER AGREE TO MAKE PAYMENTS AS REQUIRED BY TEXAS METAL BUILDINGS. PAYMENT: COD WITH DOWNPAYMENT. JOBS EXCEEDING \$50,000.00 SHALL REQUIRE PROGRESS PAYMENTS: JOBSITE INFORMATION MAY BE REQUIRED ON ANY JOB. THIS PROJECT IS BEING QUOTED USING MFG STANDARD SPECIFICATIONS UNLESS NOTED OTHERWISE. ACCEPTED BY BUYER AND THIS CONTRACT IS ENTERED INTO AT WACO TEXAS, (MCLENNAN COUNTY) BY SUBMITTING THE PURCHASE ORDER / QUOTE FORM AND CONTRACT DOCUMENTS, I HEREBY AGREE AND ACCEPT ALL TERMS AND CONDITIONS OF SALE. FABRICATION SHALL BE IN ACCORDANCE WITH MFG STANDARD UNLESS OTHERWISE NOTED, AND WILL GENERALLY CONFORM WITHIN CUSTOMARY INDUSTRY TOLERANCES, TO MBMA AND AISC 9th EDITION STANDARDS, AND/OR AS MODIFIED BY THE STANDARDS AND SPECIFICATIONS CONTAINED IN MFG'S PRODUCT DESCRIPTION(S). NOTE: ANCHOR RODS / BOLTS OR EMBEDMENT DEVICES ARE NOT INCLUDED AS PART OF THE SALE.

NOTE: IT IS THE CUSTOMER'S RESPONSIBILITY TO VERIFY THE LOADS & CODES WITH YOUR LOCAL OFFICIALS.

DRAWING DEPOSIT: \$2,000.00 BALANCE ON DELIVERY: \$5,065.71

Agreed to this _____ of _____, 20____
Customer Signature

X _____

Printed Name

By signing above hereby state I have confirmed all codes with my local building department and I accept full responsibility for the accuracy of the codes and loads as stated.

X Jeff Nibert
TEXAS METAL BUILDINGS Sales Representative

CONTRACT ACCEPTED AND ENTERED INTO
THIS _____ OF _____, 20____

X _____
TEXAS METAL BUILDINGS, Officer

****THIS QUOTE IS GOOD UNTIL 1/11/2009 ONLY AND MUST HAVE ALL PAPERWORK COMPLETED ON OR BEFORE ORDER DATE****
 Due to current steel market volatility we are not able to honor pricing beyond "order-by" dates. The current steel market is changing rapidly and we are not able to forecast when prices will stabilize. ONLY WHEN ORDER IS RELEASED FOR FABRICATION will the current/updated price be held. If the order is delayed by customer for any reason, the order is subject to re-pricing. Price of alternates will be added if checked but is not included in the proposal total. Deposit is non-refundable - please check your order for accuracy and completeness.
 Jeff Nibert REV. NO.: 10

CUSTOMER:	Jeff Nibert
JOB NUM.:	TX3055
COMPANY:	Texas Metal Buildings
JOB ADDR:	
CITY:	Seguin
COUNTY:	Guadalupe
STATE:	Texas
ZIP:	78155
DATE:	12/22/2008
CUST.#:	
PHONE:	(361) 758-3030
FAX:	(361) 758-4631
CELL:	(361) 739-4853
EMAIL:	Jeff@TexasMetalBuildings.com
DWG BY:	
REV. NO.:	DATE:

APPROVAL DRAWING PACKAGE
THIS BUILDING MEETS OR EXCEEDS:
CODE/CLASS: IBC 06

Page: 1/7 Revision No: 10

BUILD FROM DRAWINGS MARKED "FOR CONSTRUCTION" ONLY!!!

TEXAS METAL BUILDINGS
P.O. Box 1495

Aransas Pass, 78335
TX
PH: 361-758-3030
FX: 361-758-4631

Approval/Permit

Field locate items will not show up on drawings: personnel doors, windows, wall and sky lights along with ridge vents and other items may not show up on drawings. Please check your purchase order for these items.

Customer Signature: By signing below I am confirming that the required codes and loads are accurate and complete and that there are no additional requirements with regards to the codes, loads and/or design specifications as stated on the face of this document. All clearances for doors and hardware are the responsibility of the customer. Seller is not responsible for mechanical door clearances.

This order will begin fabrication approximately 10 days after we receive signed approval drawings. Once fabrication is started on the job revisions will not be allowed. A cashiers check for the balance due shall be due at delivery. You will be notified via DELIVERY NOTICE with the approximate date and account balance before delivery. If you wish to place your order on PERMIT HOLD please do so by checking the box below. Once a job is placed on permit hold the customer is responsible for contacting seller to release the job for fabrication. Placing a job on hold does not "lock" the price. The order shall be subject to standard terms and conditions supplied along with the quotation.



RELEASE FOR FABRICATION
NO CHANGES ARE REQUIRED



HOLD FOR PERMIT
NO CHANGES ARE REQUIRED



RELEASE FOR FABRICATION
CHANGES ARE REQUIRED &
I HAVE NOTED THE CHANGES
(SUBJECT TO VARIIFICATION)



HOLD FOR PERMIT
CHANGES ARE REQUIRED
I HAVE NOTED THE CHANGES
(SUBJECT TO VERIFICATION)



REVISE ORDER (HOLD)
CHANGES AND/OR REVISIONS
ARE REQUIRED & I WILL MAKE
CONTACT

APPROVED BY:

SIGNATURE: _____ DATE: _____

PRINT NAME: _____

DESIGN LOADS

BUILDING CODE:	IBC 06
ROOF DEAD LOAD:	2.5
COLLATERAL LOAD:	0.5
LIVE LOAD:	20.0
SNOW LOAD:	12.0
WIND SPEED:	90
WIND EXPOSURE:	B
IMP. WIND: 1	IMP. SEISMIC : 1
SEISMIC ZONE:	0
SEISMIC COEFF.:	0.197

BUILDING DESCRIPTION

NOMINAL WIDTH:	24'
NOMINAL LENGTH:	36'
B.S.W. HEIGHT:	9'
F.S.W. HEIGHT:	10'
ROOF SLOPE:	0.5 : 12

DRAWING INDEX		
CS-1	COVER SHEET	
N1	GENERAL NOTES	
S1	FRONT SIDEWALL ELEVATION	
S2	BACK SIDEWALL ELEVATION	
E1	LEFT ENDWALL ELEVATION	
E2	RIGHT ENDWALL ELEVATION	
D-	FLOOR PLAN	
FABRICATION NOTES		
MATERIALS	ASTM DESIGNATION	MIN. YIELD (ksi)
HR Steel Shapes	A572	Fy = 50
Steel Pipes	A500	Fy = 42
HSS Tubing	A500	Fy = 46
Struct. Web (pl)	A572/A1011	Fy = 50
Struct. Flange (pl)	A529/A572	Fy = 55
CF Light Gauge	A572/A1011	Fy = 50, 55
R&W Sheets	A792/A653	Fy = 50, 80
Cable Brace	A475 - Type1	EX Strong (HS)
Rod Brace	A36	Fy = 36
Mill Sections	A36	Fy = 36
MIN. TENSILE		
Machine Bolts/Nuts	A307	Fu = 60
HS Bolts 1" & <	A325 - Type1	Fu = 120
HS Bolts >1"-1.5"	A325 - Type1	Fu = 105

PLEASE PUT SAFETY FIRST!

WE HAVE A COMMITMENT TO MANUFACTURE QUALITY BUILDINGS THAT CAN BE SAFELY ERECTED. HOWEVER, THE SAFETY COMMITMENT AND JOB SITE PRACTICES OF THE ERECTOR ARE BEYOND OUR CONTROL. IT IS STRONGLY RECOMMENDED THAT SAFE WORKING CONDITIONS AND ACCIDENT PREVENTION PRACTICES ARE THE TOP PRIORITY OF ANY JOB SITE. LOCAL, STATE, AND FEDERAL SAFETY AND HEALTH STANDARDS SHOULD ALWAYS BE FOLLOWED TO HELP INSURE WORKERS SAFETY. MAKE CERTAIN ALL EMPLOYEES KNOW THE SAFEST AND MOST PRODUCTIVE WAY OF ERECTING A BUILDING. ALL EMPLOYEES SHOULD KNOW EMERGENCY PROCEDURES. DAILY MEETINGS HIGHLIGHTING SAFETY PROCEDURES ARE ALSO RECOMMENDED. THE USE OF HARD HATS, RUBBER SOLE SHOES FOR ROOF WORK, PROPER EQUIPMENT FOR HANDLING MATERIAL, AND SAFETY NETS WHERE APPLICABLE, ARE RECOMMENDED.

Sheeting & Trim	Skylights	Girt / Purlin Conditions	Girt / Purlin Type	Accessories	Quantity
Galvalume	Roof	No. Description	LOC.	FSW: Flush	FSW: Zee
Colony Green	Wall			Roof	BSW: Zee
	Gutter		Wall	LEW: Flush	LEW: Zee
	DS			ROOF: Flush	ROOF: Zee
Fern Green	Rake/Eave	Insulation			
	Corner	Description	LOC.	Girt / Purlin Conditions	
			Roof	FSW: 8 "	COLOR: Red oxide
Framing Color			Wall	BSW: 8 "	COLOR: Red oxide
Primary Frames				LEW: 8 "	COLOR: Red oxide
Secondary		Base Condition		ROOF: 8 "	COLOR: Red oxide
Base		Girt			
12/22/2008 :: 12:56 PM					



SAFETY FIRST!

WE HAVE A COMMITMENT TO MANUFACTURE QUALITY BUILDINGS THAT CAN BE SAFELY ERECTED. HOWEVER, THE SAFETY COMMITMENT AND JOB SITE PRACTICES OF THE ERECTOR ARE BEYOND OUR CONTROL. IT IS STRONGLY RECOMMENDED THAT SAFE WORKING CONDITIONS AND ACCIDENT PREVENTION PRACTICES ARE THE TOP PRIORITY OF ANY JOB SITE. LOCAL, STATE, AND FEDERAL SAFETY AND HEALTH STANDARDS SHOULD ALWAYS BE FOLLOWED TO HELP INSURE WORKERS SAFETY. MAKE CERTAIN ALL EMPLOYEES KNOW THE SAFEST AND MOST PRODUCTIVE WAY OF ERECTING A BUILDING. ALL EMPLOYEES SHOULD KNOW EMERGENCY PROCEDURES. DAILY MEETINGS HIGHLIGHTING SAFETY PROCEDURES ARE ALSO RECOMMENDED. THE USE OF HARD HATS, RUBBER SOLE SHOES FOR ROOF WORK, PROPER EQUIPMENT FOR HANDLING MATERIAL, AND SAFETY NETS WHERE APPLICABLE, ARE RECOMMENDED.

BUYER/END USE CUSTOMER RESPONSIBILITIES
MANUFACTURER HEREINAFTER REFERRED TO AS MFG
IT IS THE RESPONSIBILITY OF THE BUYER/END USE CUSTOMER TO OBTAIN APPROPRIATE APPROVALS AND SECURE NECESSARY PERMITS FROM CITY, COUNTY, STATE, OR FEDERAL AGENCIES AS REQUIRED, AND TO ADVISE/RELEASE MFG TO FABRICATE UPON RECEIVING SUCH.

MFG STANDARD SPECIFICATIONS APPLY UNLESS STIPULATED OTHERWISE IN THE CONTRACT DOCUMENTS. MFG DESIGN, FABRICATION, QUALITY CRITERIA, STANDARDS, PRACTICE, METHODS AND TOLERANCES SHALL GOVERN THE WORK WITH ANY OTHER INTERPRETATIONS TO THE CONTRARY NOTWITHSTANDING. IT IS UNDERSTOOD BY BOTH PARTIES THAT THE BUYER/END USE CUSTOMER IS RESPONSIBLE FOR CLARIFICATION OF INCLUSIONS OR EXCLUSIONS FROM THE ARCHITECTURAL PLANS AND/OR SPECIFICATIONS. IN CASE OF DISCREPANCIES BETWEEN MFG STRUCTURAL STEEL PLANS AND PLANS FOR OTHER TRADES, MFG PLANS SHALL GOVERN. (SECTION 3 AISC CODE OF STANDARD PRACTICES, 9TH EDITION)

APPROVAL OF MFG DRAWINGS AND CALCULATIONS INDICATES THAT MFG HAS CORRECTLY INTERPRETED AND APPLIED THE CONTRACT DOCUMENTS. THIS APPROVAL CONSTITUTES THE BUYER/END USE CUSTOMER ACCEPTANCE OF THE MFG DESIGN CONCEPTS, ASSUMPTIONS, AND LOADING. (SECTION 4 AISC CODE AND MBMA 3.3.3)

ONCE THE BUYER/END USE CUSTOMER HAS SIGNED MFG APPROVAL PACKAGE THE PROJECT IS RELEASED FOR FABRICATION, AND CHANGES SHALL BE BILLED TO THE BUYER/END USE CUSTOMER INCLUDING MATERIAL, ENGINEERING AND OTHER COSTS. AN ADDITIONAL FEE MAY BE CHARGED IF THE PROJECT MUST BE MOVED FROM THE FABRICATION AND SHIPPING SCHEDULE.

THE BUYER/END USE CUSTOMER IS RESPONSIBLE FOR OVERALL PROJECT COORDINATION, ALL INTERFACE, COMPATIBILITY, AND DESIGN CONSIDERATIONS CONCERNING ANY MATERIALS NOT FURNISHED BY MFG AND MFG STEEL SYSTEMS ARE TO BE CONSIDERED AND COORDINATED BY THE BUYER/END USE CUSTOMER. SPECIFIC DESIGN CRITERIA CONCERNING THIS INTERFACE BETWEEN MATERIALS MUST BE FURNISHED BEFORE RELEASE FOR FABRICATION OR MFG ASSUMPTIONS WILL GOVERN (SECTION 4 AND COMMENTARY, AISC CODE OF STANDARD PRACTICE 9TH EDITION)

IT IS THE RESPONSIBILITY OF THE BUYER/END USE CUSTOMER TO INSURE THAT MFG PLANS COMPLIES WITH THE APPLICABLE REQUIREMENTS OF ANY GOVERNING BUILDING AUTHORITIES. THE SUPPLYING OF SEALED ENGINEERING DATA AND DRAWINGS FOR THE METAL BUILDING SYSTEM DOES NOT IMPLY OR CONSTITUTE AN AGREEMENT THAT MFG OR ITS DESIGN ENGINEER IS ACTING AS THE ENGINEER OF RECORD OR DESIGN PROFESSIONAL FOR A CONSTRUCTION PROJECT. THESE DRAWINGS ARE SEALED ONLY TO CERTIFY THE DESIGN OF THE STRUCTURAL COMPONENTS FURNISHED BY MFG.

THE BUYER/END USE CUSTOMER IS RESPONSIBLE FOR SETTING OF ANCHOR BOLTS AND ERECTION OF STEEL IN ACCORDANCE WITH MFG "FOR CONSTRUCTION" DRAWINGS ONLY. TEMPORARY SUPPORTS SUCH AS GUYS, BRACES, FALSE WORK, CRIBBING OR OTHER ELEMENTS REQUIRED FOR THE ERECTION OPERATION SHALL BE DETERMINED FURNISHED AND INSTALLED BY THE ERECTOR. NO ITEMS SHOULD BE PURCHASED FROM A PRELIMINARY SET OF DRAWINGS, INCLUDING ANCHOR BOLTS. USE ONLY FINAL "FOR CONSTRUCTION DRAWINGS" FOR THE USE. (SECTION 7 AISC CODE OF STANDARD PRACTICE, 9TH EDITION)

MFG IS RESPONSIBLE FOR THE DESIGN OF THE ANCHOR BOLT TO PERMIT THE TRANSFER OF FORCES BETWEEN THE BASE PLATE AND THE ANCHOR BOLT IN SHEAR, BEARING AND TENSION, BUT IS NOT RESPONSIBLE FOR THE TRANSFER OF ANCHOR BOLT FORCES TO THE CONCRETE OR THE ADEQUACY OF THE ANCHOR BOLT IN RELATION TO THE CONCRETE.

UNLESS OTHERWISE PROVIDED IN THE ORDER DOCUMENTS, MFG DOES NOT DESIGN AND IS NOT RESPONSIBLE FOR THE DESIGN, MATERIAL AND CONSTRUCTION OF THE FOUNDATION OR FOUNDATION EMBEDMENT. THE END USE CUSTOMER SHOULD ASSURE HIMSELF THAT ADEQUATE PROVISIONS ARE MADE IN THE FOUNDATION DESIGN FOR LOADS IMPOSED BY COLUMN REACTIONS OF THE BUILDING, OTHER IMPOSED LOADS, AND BEARING CAPACITY OF THE SOIL AND OTHER CONDITIONS OF THE BUILDING SITE.

IT IS RECOMMENDED THAT A PROFESSIONAL ENGINEER EXPERIENCED IN THE DESIGN OF SUCH STRUCTURES DESIGN THE ANCHORAGE AND FOUNDATION OF THE BUILDING. (SECTION A10 1996 MBMA LOW RISE BUILDING SYSTEMS MANUAL)

NORMAL ERECTION OPERATIONS INCLUDE THE CORRECTIONS OF MINOR MISFITS BY MODERATE AMOUNTS OF REAMING, CHIPPING, WELDING OR CUTTING, AND THE DRAWING OF ELEMENTS INTO LINE THROUGH THE USE OF DRIFT PINS. ERRORS WHICH CANNOT BE CORRECTED BY THE FOREGOING MEANS OR WHICH REQUIRE MAJOR CHANGES IN MEMBER CONFIGURATION ARE TO BE REPORTED IMMEDIATELY TO MFG BY THE BUYER/END USE CUSTOMER, TO ENABLE WHOEVER IS RESPONSIBLE EITHER TO CORRECT THE ERROR OR THE APPROVE THE MOST EFFICIENT AND ECONOMIC METHOD OF CORRECTION TO BE USED BY OTHERS. (SECTION 7 AISC CODE OF STANDARD PRACTICE, 9TH EDITION) NEITHER THE FABRICATOR NOR THE BUYER/END USE CUSTOMER WILL CUT, DRILL OR OTHERWISE ALTER HIS WORK, OR THE WORK OF OTHER TRADES, TO ACCOMMODATE OTHER TRADES, UNLESS SUCH WORK IS CLEARLY SPECIFIED. THE BUYER/END USE CUSTOMER IS RESPONSIBLE FOR FURNISHING COMPLETE INFORMATION AS TO MATERIALS, SIZE LOCATION AND NUMBER OF ALTERATIONS PRIOR TO PREPARATION OF SHOP DRAWINGS. (SECTION 7 AISC CODE OF STANDARD PRACTICE, 9TH EDITION)

SAFETY COMMITMENT
MFG HAS A COMMITMENT TO MANUFACTURE QUALITY BUILDINGS THAT CAN BE SAFELY ERECTED. HOWEVER, THE SAFETY COMMITMENT AND JOB SITE PRACTICES OF THE ERECTOR ARE BEYOND THE CONTROL OF MFG. IT IS STRONGLY RECOMMENDED THAT SAFE WORKING CONDITIONS AND ACCIDENT PREVENTION PRACTICES ARE THE TOP PRIORITY OF ANY JOB SITE. LOCAL, STATE, AND FEDERAL SAFETY AND HEALTH STANDARDS SHOULD ALWAYS BE FOLLOWED TO HELP INSURE WORKERS SAFETY. MAKE CERTAIN ALL EMPLOYEES KNOW THE SAFEST AND MOST PRODUCTIVE WAY OF ERECTING A BUILDING. ALL EMPLOYEES SHOULD KNOW EMERGENCY PROCEDURES. DAILY MEETINGS HIGHLIGHTING SAFETY PROCEDURES ARE ALSO RECOMMENDED. THE USE OF HARD HATS, RUBBER SOLE SHOES FOR ROOF WORK, PROPER EQUIPMENT FOR HANDLING MATERIAL, AND SAFETY NETS WHERE APPLICABLE, ARE RECOMMENDED.

NOTES: APPLIES TO ALL ELEVATIONS
1. DO NOT CUT, REMOVE OR RELOCATE GIRTS OR X-BRACING. NO ADDITIONAL OPENINGS ALLOWED WITHOUT WRITTEN APPROVAL FROM THE STEEL BUILDING MANUFACTURER.

2. HARDWARE SUCH AS WINDOWS, OVERHEAD DOORS, AND ASSOCIATED ATTACHMENTS THAT ARE AND ASSOCIATED ATTACHMENTS THAT ARE SUPPLIED BY OTHERS MUST HAVE THE SAME LEVEL OF WIND RESISTANCE AS WALL PANELS.

3. WORKERS SHALL NOT HAVE THEIR WEIGHT ON FRAMES OR INDIVIDUAL COLUMNS UNTIL THEY HAVE BEEN SECURED WITH GIRTS AND CROSS BRACING.

NOTES: APPROVAL DRAWINGS: * APPROVAL ORDERS MUST BE RELEASED FOR FABRICATION WITHIN FIVE (5) CALENDAR DAYS AFTER THE SUBMITTAL DRAWINGS ARE ISSUED OR THEY WILL BE SUBJECT TO ANY CURRENT PRICE INCREASES. SPECIAL ATTENTION SHOULD BE GIVEN IN APPROVING DIMENSIONS AND/OR DETAILS.

BUILDERS RESPONSIBILITIES
THE BUYER / END USER / BUILDER MUST SECURE ALL REQUIRED APPROVALS AND PERMITS FROM THE APPROPRIATE AGENCY AS REQUIRED. APPROVAL OF MFG DRAWINGS AND CALCULATIONS INDICATES THAT MFG HAS CORRECTLY INTERPRETED AND APPLIED THE REQUIREMENTS OF THE CONTRACT DRAWINGS AND SPECIFICATIONS. (SECT. 4.2.1 AISC CODE OF STANDARD PRACTICE, 9TH EDITION) WHERE DISCREPANCIES EXIST BETWEEN MFG STRUCTURAL STEEL PLANS AND THE PLANS OF OTHER TRADES, THE STRUCTURAL STEEL PLANS WILL GOVERN. (SECT. 3.3 AISC CODE OF STANDARD PRACTICE, 9TH EDITION). DESIGN CONSIDERATIONS OF ANY MATERIALS IN THE STRUCTURE WHICH ARE NOT FURNISHED BY MFG ARE THE RESPONSIBILITY OF THE BUILDER AND ENGINEERS OTHER THAN MFG ENGINEERING UNLESS SPECIFICALLY INDICATED. THE BUYER/END USE CUSTOMER IS RESPONSIBLE FOR ALL ERECTION OF STEEL AND ASSOCIATED WORK IN COMPLIANCE WITH MFG "CONSTRUCTION DRAWINGS".

MFG 'S' STANDARD PRODUCT SPECIFICATIONS APPLY AND UNLESS STIPULATED OTHERWISE IN THE CONTRACT DOCUMENTS, MFG 'S' DESIGN, FABRICATION, QUALITY CRITERIA STANDARDS AND TOLERANCES WILL GOVERN THE WORK. IN CASE OF DISCREPANCIES BETWEEN MFG 'S' STRUCTURAL PLANS AND PLANS FOR OTHER TRADES MFG 'S' PLANS SHALL GOVERN.

IT IS THE RESPONSIBILITY OF THE BUYER/END USE CUSTOMER TO OBTAIN APPROPRIATE APPROVALS AND NECESSARY PERMITS FROM CITY, COUNTY, STATE, OR FEDERAL AGENCIES, AS REQUIRED. APPROVAL OF METAL MFG 'S' DRAWINGS CONSTITUTES THE BUYER/END USE CUSTOMER'S ACCEPTANCE OF MFG 'S' INTERPRETATION OF THE CONTRACT PURCHASE ORDER.

ONCE THE BUYER/END USE CUSTOMER OR A/E FIRM HAS SIGNED MFG 'S' APPROVAL PACKAGE, CHANGES FROM THE PURCHASE ORDER BY THE BUILDER WILL BE BILLED TO THE BUYER/END USE CUSTOMER FOR MATERIAL, ENGINEERING AND HANDLING FEES. SUCH CHANGES MAY CAUSE THE PROJECT TO BE MOVED FROM THE FABRICATION AND /OR SHIPPING SCHEDULE. A PENALTY FEE MAY BE CHARGED IF THE PROJECT MUST BE MOVED FROM THE FABRICATION AND /OR SHIPPING SCHEDULE.

THE BUYER/END USE CUSTOMER OR A/E FIRM IS RESPONSIBLE FOR THE OVERALL PROJECT CONDITION. ALL INTERFACE AND COMPATIBILITY CONCERNING ANY MATERIALS NOT FURNISHED BY MFG ARE TO BE CONSIDERED AND COORDINATED BY THE BUYER/END USE CUSTOMER OR A/E FIRM. MFG ASSUMPTIONS SHALL ALWAYS GOVERN.

THE BUYER/END USE CUSTOMER IS RESPONSIBLE TO INSURE THAT ALL OTHER PROJECT PLANS AND SPECIFICATIONS COMPLY WITH THE APPLICABLE REQUIREMENTS OF ANY GOVERNING BUILDING AUTHORITY. SUPPLYING DRAWINGS BY MFG DOES NOT IMPLY OR CONSTITUTE AN AGREEMENT THAT MFG OR ITS DESIGN ENGINEER IS ACTING AS THE ENGINEER OF RECORD OR DESIGN PROFESSIONAL FOR THE CONSTRUCTION PROJECT. THESE DRAWINGS AND DESIGN DATA ARE FURNISHED BY MFG IN COMPLIANCE WITH ALL REQUIREMENTS OF THE PURCHASE ORDER.

THE BUYER/END USE CUSTOMER IS RESPONSIBLE FOR SETTING OF ANCHOR BOLTS AND ERECTION OF STEEL BUILDING COMPONENTS IN ACCORDANCE WITH MFG 'S' "FOR CONSTRUCTION" DRAWINGS ONLY. TEMPORARY SUPPORTS OR BRACING REQUIRED FOR THE BUILDING ERECTION WILL BE THE RESPONSIBILITY OF THE ERECTOR TO DETERMINE, FURNISH, AND INSTALL. MFG DOES NOT WARRANT STRUCTURAL INTEGRITY OF ANY COMPONENTS FIELD MODIFIED OR DESIGNED AND FABRICATED BY OTHERS. NEITHER DO WE ACCEPT DESIGN RESPONSIBILITY FOR THE EFFECTS NON STANDARD COMPONENTS DESIGNED BY OTHERS MAY HAVE ON THE SYSTEM IN GENERAL.

PRIMER
SHOP PRIMER PAINT IS A RUST INHIBITIVE PRIMER, WHICH MEETS THE END PERFORMANCE OF FEDERAL SPECIFICATION TT-P-636 AND IS MFG RED OXIDE COLOR. THIS PAINT IS NOT INTENDED FOR LONG-TERM EXPOSURE TO THE ELEMENTS. MFG IS NOT RESPONSIBLE FOR ANY DETERIORATION OF THE SHOP PRIMER PAINT AS A RESULT OF IMPROPER HANDLING AND/OR STORAGE. MFG SHALL NOT BE RESPONSIBLE FOR ANY FIELD APPLIED PAINT AND/OR COATINGS. (SECTION 6.5 AISC CODE OF STANDARD PRACTICE 9TH EDITION) NORMAL THICKNESS OF PRIMER SHALL BE 1 MIL UNLESS OTHERWISE SPECIFIED IN CONTRACT DOCUMENTS.

GALVANIZED OR SPECIAL COATINGS
SEE CONTRACT DOCUMENTS.

ALL BOLTS ARE 0' 0-1/2" DIA. X 0'-1" A307 EXCEPT:

- A) EAVE STRUT CONNECTION - 1/2" X 0'-1-1/2" A307
- B) END WALL RAFTER SPLICE - 5/8" X 0'-1-3/4" A325-N
- C) END WALL COL/RAFT CONNECTION - 1/2" X 0' - 1-1/4" A325-N
- D) MAIN FRAME CONNECTIONS - SEE CROSS SECTION

A325 BOLT TIGHTENING REQUIREMENTS
ALL HIGH STRENGTH BOLTS ARE A325-N UNLESS NOTED OTHERWISE.

STRUCTURAL BOLTS SHALL BE TIGHTENED BY THE TURN-OF-THE-NUT METHOD IN ACCORDANCE WITH THE 9TH EDITION AISC "SPECIFICATION FOR STRUCTURAL JOINTS" USING ASTM A 325 OR A490 BOLTS, WHEN SPECIFICALLY REQUIRED. A325-N BOLTS ARE SUPPLIED WITHOUT WASHER UNLESS NOTED ON THE DRAWINGS AS PROVIDED BY MFG.

ALL BOLTED CONNECTIONS UNLESS NOTED ARE DESIGNED AS BEARING TYPE CONNECTIONS WITH THREADS NOT EXCLUDED FROM THE SHEAR PLANE.

CLOSURE STRIPS ARE FURNISHED ONLY IF NOTED ON SHIPPING DOCUMENTS

INSIDE - UNDER ROOF PANELS AT EAVE
OUTSIDE - BETWEEN END WALL PANELS AND RAKE TRIM
UNDER CONTINUOUS RIDGE VENT SKIRTS

ERECTION NOTE:
ALL BRACING, STRAPPING, & BRIDGING SHOWN AND PROVIDED BY MFG FOR THIS BUILDING IS REQUIRED AND SHALL BE INSTALLED BY THE ERECTOR AS A PERMANENT PART OF THE STRUCTURE. IF ADDITIONAL BRACING IS REQUIRED FOR STABILITY DURING ERECTION, IT SHALL BE THE ERECTOR'S RESPONSIBILITY TO DETERMINE THE AMOUNT OF SUCH BRACING AND TO PROCURE AND INSTALL AS NEEDED.

ERECTION AND UNLOADING NOT BY MFG

SHORTAGES
ANY CLAIMS OR SHORTAGES BY BUYER MUST BE MADE TO MFG WITHIN SEVEN (7) DAYS AFTER DELIVERY, OR SUCH CLAIMS SHALL BE CONSIDERED WAIVED BY THE CUSTOMER AND DISALLOWED.

CORRECTIONS OF ERRORS AND REPAIRS (MBMA 6.10)
CLAIMS FOR CORRECTION OF ALLEGED MISFITS WILL BE DISALLOWED UNLESS MFG SHALL HAVE RECEIVED PRIOR NOTICE THEREOF AND ALLOWED REASONABLE INSPECTION OF SUCH MISFITS. THE CORRECTION OF MINOR MISFITS BY THE USE OF DRIFT PINS TO DRAW THE COMPONENTS INTO LINE, MODERATE AMOUNTS OF REAMING, CHIPPING, SHIMMING AND CUTTING, AND THE REPLACEMENT OF MINOR SHORTAGES OF MATERIAL ARE A NORMAL PART OF ERECTION AND ARE NOT SUBJECT TO CLAIM. NO PART OF THE BUILDING MAY BE RETURNED FOR ALLEGED MISFITS WITHOUT THE PRIOR APPROVAL OF MFG.

BUILDING SPECIFICATIONS
THE STRUCTURE UNDER THIS CONTRACT HAS BEEN DESIGNED AND DETAILED FOR THE LOADS AND CONDITIONS STIPULATED IN THE CONTRACT AND SHOWN ON THESE DRAWINGS. ANY ALTERATIONS TO THE STRUCTURAL SYSTEM OR REMOVAL OF ANY COMPONENT PARTS OR THE ADDITION OF OTHER CONSTRUCTION MATERIALS OR LOADS MUST BE DONE UNDER THE ADVICE OF A REGISTERED ARCHITECT, CIVIL OR STRUCTURAL ENGINEER. MFG WILL NOT ASSUME RESPONSIBILITY FOR ANY LOADS NOT INDICATED.

WARNING
INSTALL THIS BUILDING AND ALL ITS PARTS PER THESE DRAWINGS. NO CHANGES SHOULD BE MADE TO THIS BUILDING SYSTEM UNLESS APPROVED IN WRITING BY THE MANUFACTURER'S ENGINEERS. UNAPPROVED CHANGES COULD RESULT IN UNSAFE BUILDING DESIGN AND COULD ENDANGER PUBLIC SAFETY.

IN NO CASE SHOULD GALVALUME STEEL PANELS BE USED IN CONJUNCTION WITH LEAD OR COPPER. BOTH LEAD AND COPPER HAVE HARMFUL CORROSIVE EFFECTS ON THE GALVALUME ALLOY COATING WHEN THEY ARE IN CONTACT WITH GALVALUME STEEL PANELS. EVEN RUN-OFF FROM COPPER FLASHING, WIRING, OR TUBING ONTO GALVALUME SHOULD BE AVOIDED.



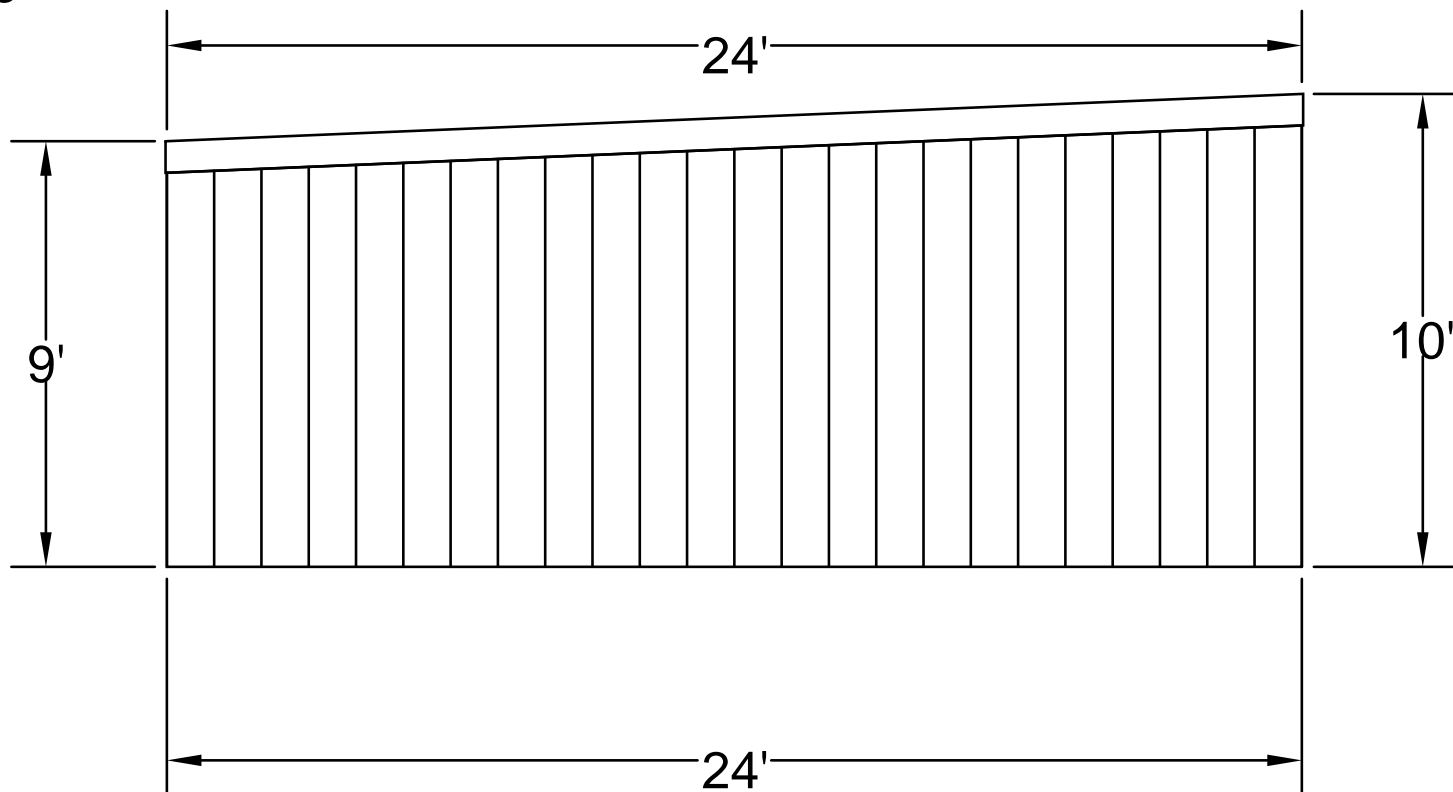
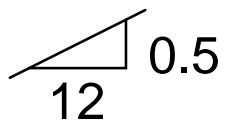

TEXAS METAL BUILDINGS
P.O. Box 1495

Aransas Pass, 78335
TX
PH: 361-758-3030
FX: 361-758-4631

Check One:
 Approved as designed Approved as noted
(subject to verification)

Approved by: _____
 End Use Customer Signature

PROJECT: 24 x 36 Shedrow	JOB NO.: TX3055
DESCRIPTION: Left end wall	
SIZE: 24' x 36' x left eave height: 9', right eave height: 10', p	
CUSTOMER: Jeff Nibert	
LOCATION: Seguin, 78155	
DATE: 12/22/2008	REV. NO.: 10
SHEET NO.: 3/7	



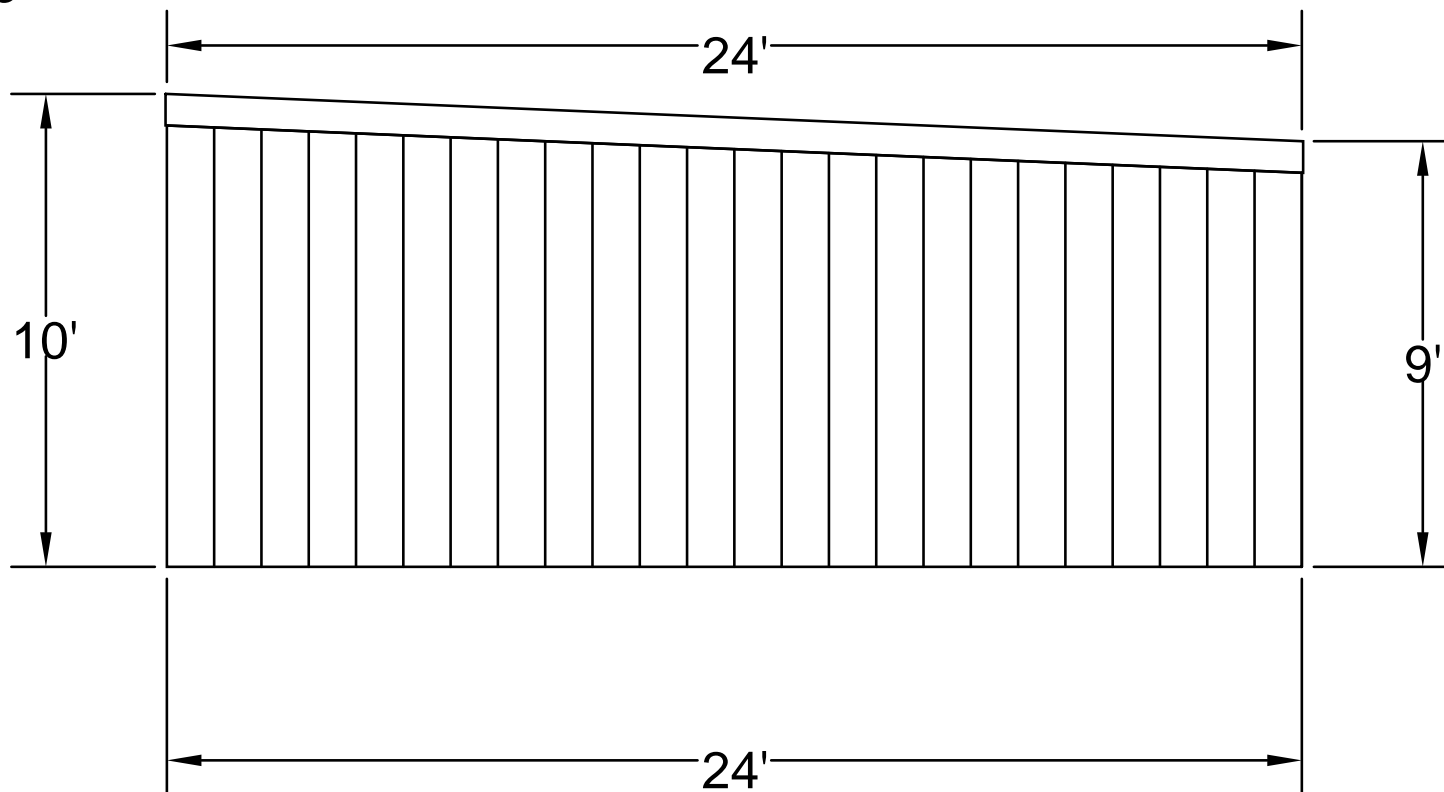
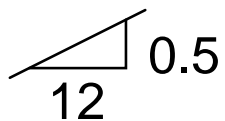

TEXAS METAL BUILDINGS
P.O. Box 1495

Aransas Pass, 78335
TX
PH: 361-758-3030
FX: 361-758-4631

Check One:
 Approved as designed Approved as noted
(subject to verification)

Approved by: _____
 End Use Customer Signature

PROJECT: 24 x 36 Shedrow	JOB NO.: TX3055
DESCRIPTION: Right end wall	
SIZE: 24' x 36' x left eave height: 9', right eave height: 10', p	
CUSTOMER: Jeff Nibert	
LOCATION: Seguin, 78155	
DATE: 12/22/2008	REV. NO.: 10
SHEET NO.: 4/7	



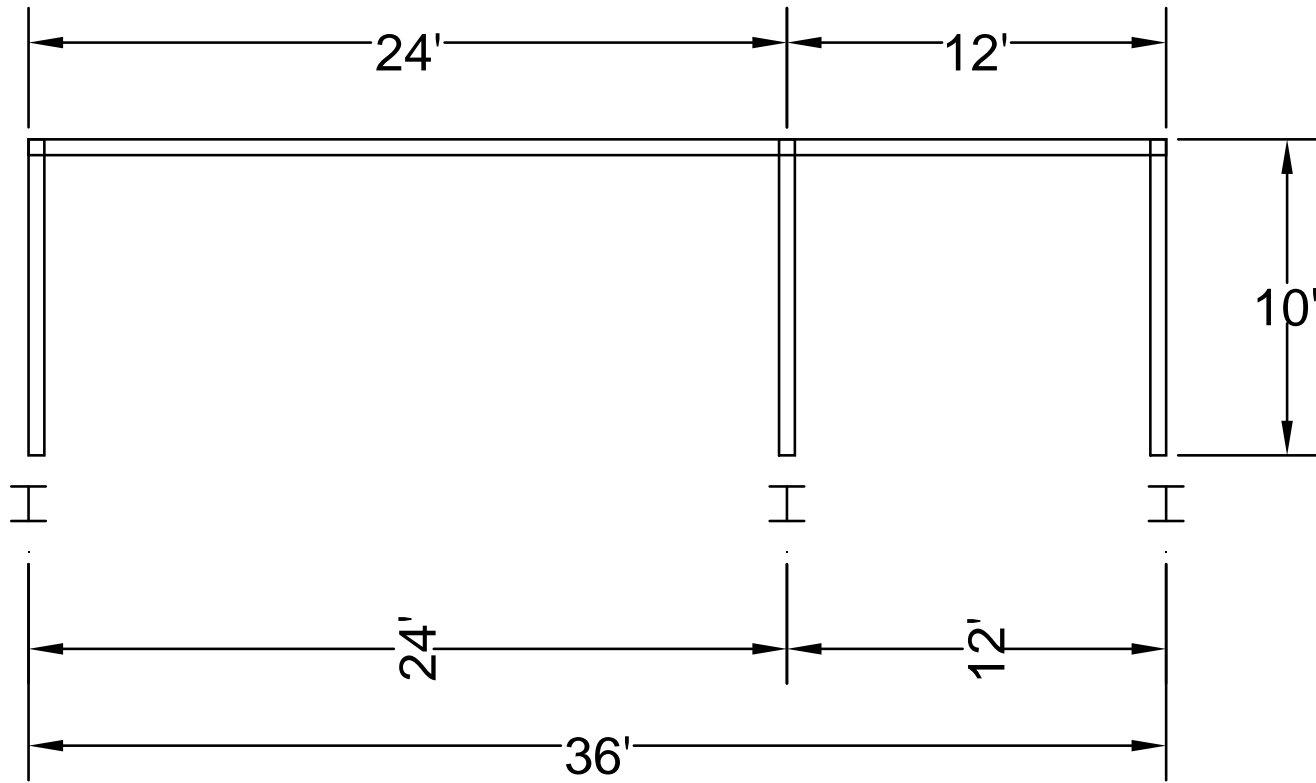

TEXAS METAL BUILDINGS
P.O. Box 1495

Aransas Pass, 78335
TX
PH: 361-758-3030
FX: 361-758-4631

Check One:
 Approved as designed Approved as noted
(subject to verification)

Approved by: _____
 End Use Customer Signature

PROJECT: 24 x 36 Shedrow	JOB NO.: TX3055
DESCRIPTION: Front side wall	
SIZE: 24' x 36' x left eave height: 9', right eave height: 10', p	
CUSTOMER: Jeff Nibert	
LOCATION: Seguin, 78155	
DATE: 12/22/2008	REV. NO.: 10
SHEET NO.: 5/7	



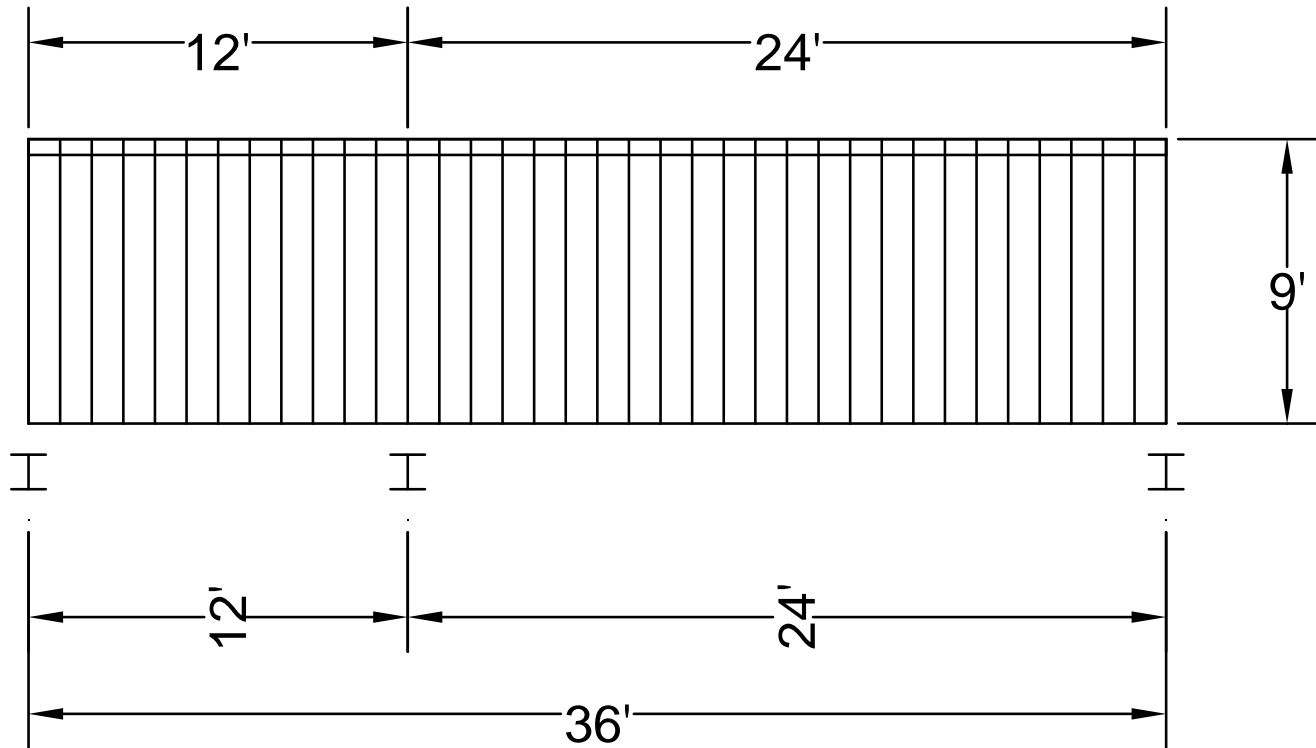

TEXAS METAL BUILDINGS
P.O. Box 1495

Aransas Pass, 78335
TX
PH: 361-758-3030
FX: 361-758-4631

Check One:
 Approved as designed Approved as noted
(subject to verification)

Approved by: _____
 End Use Customer Signature

PROJECT: 24 x 36 Shedrow	JOB NO.: TX3055
DESCRIPTION: Back side wall	
SIZE: 24' x 36' x left eave height: 9', right eave height: 10', p	
CUSTOMER: Jeff Nibert	
LOCATION: Seguin, 78155	
DATE: 12/22/2008	REV. NO.: 10
SHEET NO.: 6/7	



Back side wall

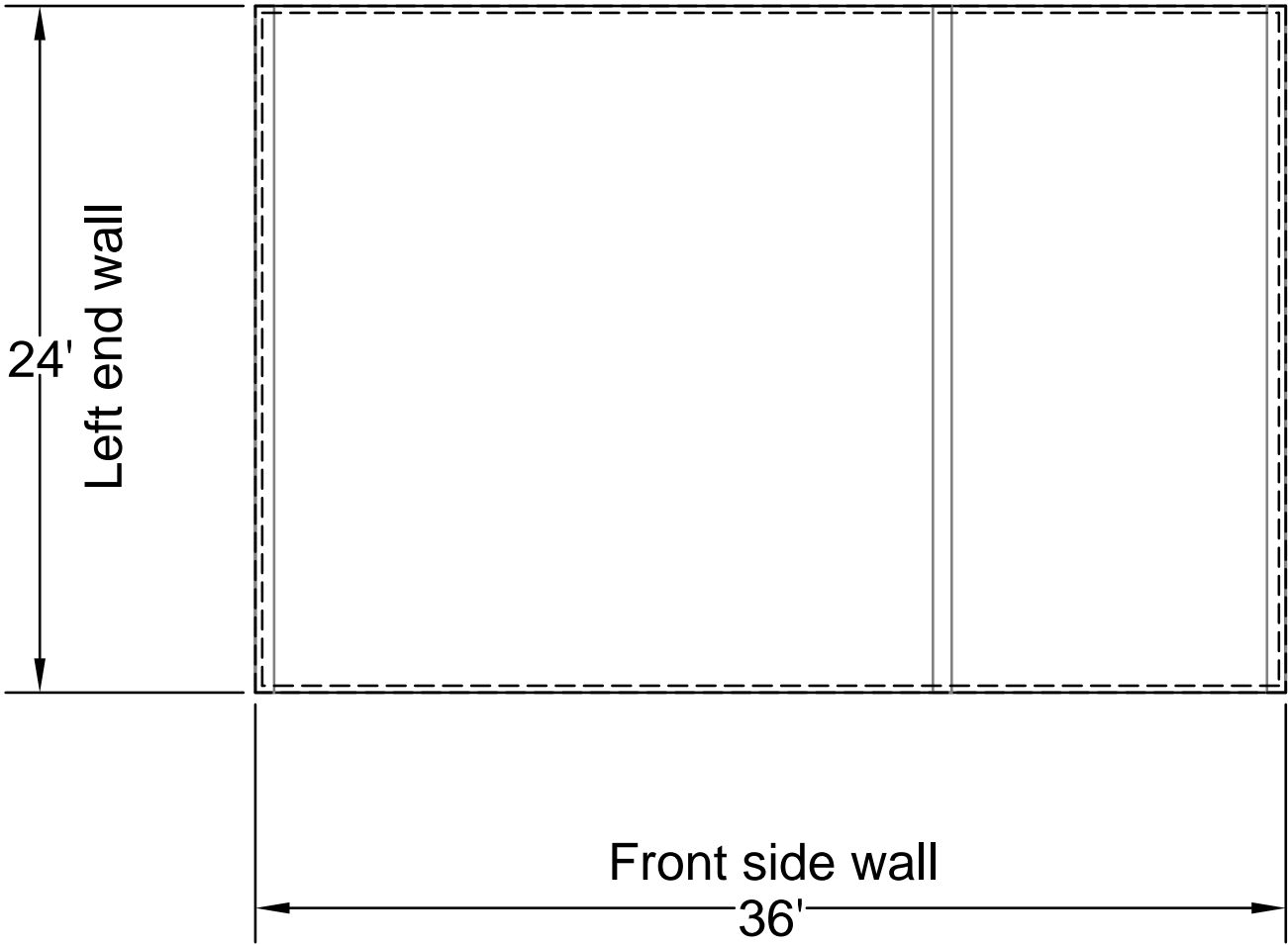

24'
Left end wall

Right end wall

Front side wall
36'

TEXAS METAL BUILDINGS
 P.O. Box 1495
 Aransas Pass, 78335
 TX
 PH: 361-758-3030
 FX: 361-758-4631

Check One:
 Approved as designed Approved as noted
(subject to verification)

Approved by: _____
 End Use Customer Signature

PROJECT: 24 x 36 Shedrow	JOB NO.: TX3055
DESCRIPTION: Floor plan	
SIZE: 24' x 36' x left eave height: 9', right eave height: 10', p	
CUSTOMER: Jeff Nibert	
LOCATION: Seguin, 78155	
DATE: 12/22/2008	REV. NO.: 10
SHEET NO.: 7/7	

